

InGaAs APD Module

Model: OPR800-1064-150-Z

Features

- Sensitivity: $\geq 250\text{kV/W}$
- Bandwidth: 150Mhz
- Si APD: 400 to 1100nm
- Low noise
- High reliability
- TO8 package with flat window

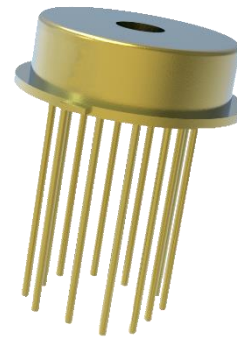

Applications

- LIDAR
- Laser finding
- Free space optical communication

Absolute Maximum Ratings

Parameter	Unit	Symbol	Rating
Reverse breakdown voltage	V	V_R	V_{BR}
Operating temperature	$^{\circ}\text{C}$	T_C	-40~+85
Storage temperature	$^{\circ}\text{C}$	T_{STG}	-55~+100
Maximum optical input power	mW	P_{in}	100
Module mains voltage	V	V_{cc}/V_{EE}	± 5
Power dissipation	mW	P_w	250
Soldering temperature(time)	$^{\circ}\text{C}$	-	300 (10s)

Optical/Electrical Characteristics ($T=25^{\circ}\text{C}$, unless otherwise stated)

Parameter	Symbol	Value			Unit	Test conditions
		Min.	Typ.	Max.		
Response Spectrum	λ	400~1100			nm	
Active Diameter	D		800		μm	
Reverse breakdown voltage	V_{BR}	350		460	V	
Operating voltage	V_R	$0.95 \times V_{BR}$			V	M=100
Responsivity	R_V		250		kV/W	M=100,1.064 μm @ $\tau=10\text{ns}$
Dynamic range	DY	25			dB	M=100,1.064 μm @ $\tau=10\text{ns}$
-3dB bandwidth	BW		150		Mhz	M=100,1.064 μm @ $\tau=100\text{ns}$
Rise/Fall time	t_r		2.3		ns	10%~90%

Noise Equivalent Power	NEP		150		fW/ $\sqrt{\text{Hz}}$	$M=100, f=100\text{kHz to } f_{3\text{db}}, \Delta = 1\text{hz}$
Output impedance	R_O		50		Ω	
Output Voltage Swing	V_O	0.7			V	
Positive Supply Current	I_{CC}			30	mA	
Negative Supply Current	I_{EE}			10	mA	50 Ω Load
Temperature coefficient of V_{op} for constant gain	γ		2.4	3.0	V/ $^{\circ}\text{C}$	-45 $^{\circ}\text{C} \sim +80^{\circ}\text{C}$
Concentricity	ΔD			30	μm	

Schematic Block Diagram

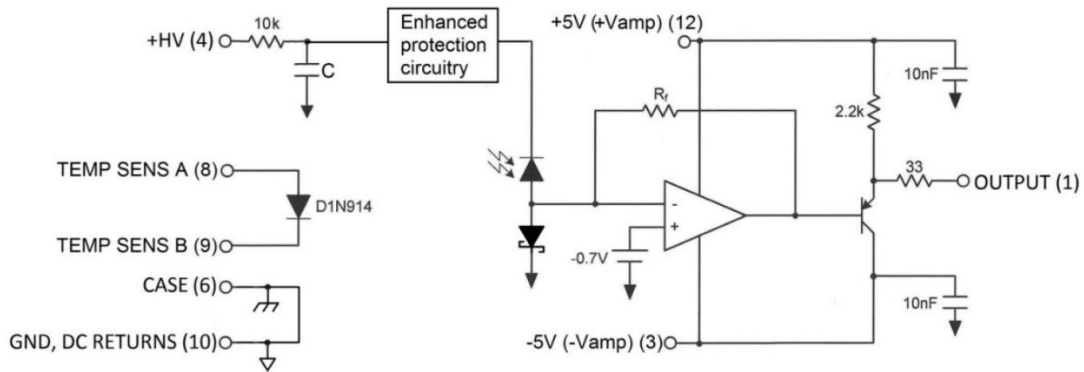

Block Diagram and Pin description

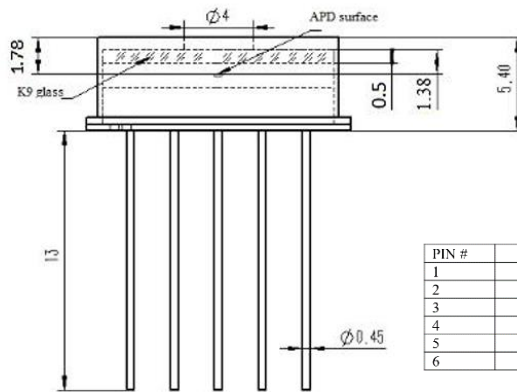

Pin description

PIN #	DESC	PIN #	DESC
1	OUTPUT	7	NC
2	NC	8	TEMP SENS A
3	-5V	9	TEMP SENS B
4	HV, APD BIAS	10	GND
5	NC	11	NC
6	CASE	12	+5V

